

Vehicle Speed Sensor (VSS) location view manual transmission

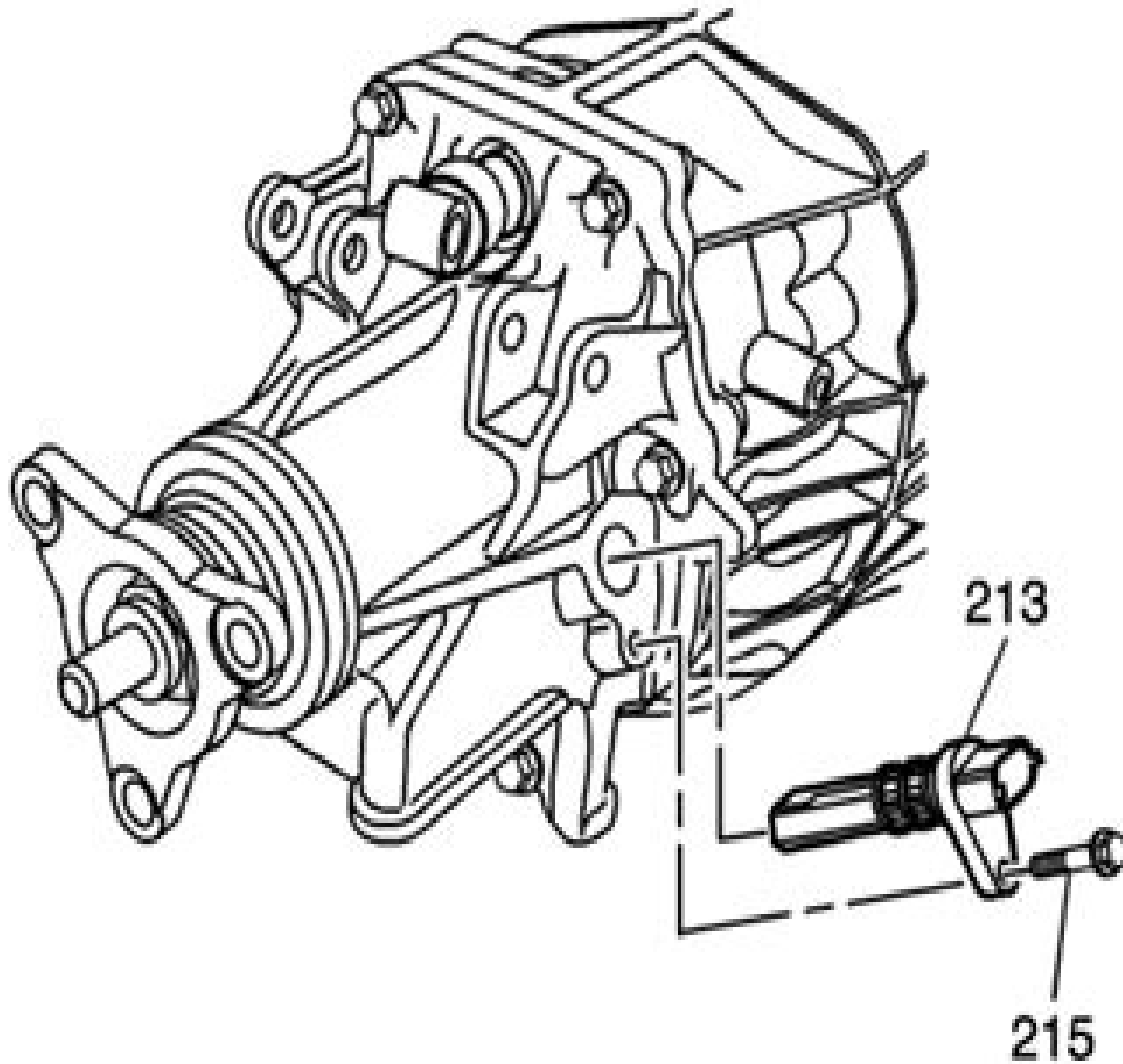

Toyota Echo Manual Transmission Removal

J Dewey



Toyota Echo Manual Transmission Removal:

Lemon-Aid New and Used Cars and Trucks 2007-2018 Phil Edmonston,2018-02-03 Steers buyers through the the confusion and anxiety of new and used vehicle purchases like no other car and truck book on the market Dr Phil along with George Iny and the Editors of the Automobile Protection Association pull no punches **Black Enterprise** ,1999-11 **BLACK ENTERPRISE** is the ultimate source for wealth creation for African American professionals entrepreneurs and corporate executives Every month **BLACK ENTERPRISE** delivers timely useful information on careers small business and personal finance Lemon-Aid Used Cars/Minivans 2003 Phil Edmonston,2002-03 **Car and Driver** ,2006 Lemon-Aid Used Cars and Trucks 2011-2012 Phil Edmonston,2011-04-25 As Toyota skids into an ocean of problems and uncertainty continues in the U S automotive industry Lemon Aid Used Cars and Trucks 20112012 shows buyers how to pick the cheapest and most reliable vehicles from the past 30 years Lemon Aid guides are unlike any other car and truck books on the market Phil Edmonston Canada s automotive Dr Phil for 40 years pulls no punches Like five books in one Lemon Aid Used Cars and Trucks is an expos of car scams and gas consumption lies a do it yourself service manual an independent guide that covers beaters lemons and collectibles an archive of secret service bulletins granting free repairs and a legal primer that even lawyers cant beat Phil delivers the goods on free fixes for Chrysler Ford and GM engine transmission brake and paint defects lets you know about Corvette and Mustang tops that fly off gives the lowdown on Honda Hyundai and Toyota engines and transmissions and provides the latest information on computer module glitches **Automotive Engineering International** ,2006 Lemon-Aid New and Used Cars and Trucks 2007-2017 Phil Edmonston,2017-03-11 Steers buyers through the the confusion and anxiety of new and used vehicle purchases like no other car and truck book on the market Dr Phil along with George Iny and the Editors of the Automobile Protection Association pull no punches **Lemon Aid Guide 2004 Used Cars and Minivans** Phil Edmonston,2003-03 **Popular Mechanics** ,1999-12 **Popular Mechanics** inspires instructs and influences readers to help them master the modern world Whether it s practical DIY home improvement tips gadgets and digital technology information on the newest cars or the latest breakthroughs in science **PM** is the ultimate guide to our high tech lifestyle **Brandfaces** ,2006 U.S. News & World Report ,2006 **Automobile Book 2002** Consumer guide,2002 This 2002 edition of the only complete new car buying guide includes profiles and photos of new models retail and dealer invoice prices mileage ratings warranties and safety features Also includes consumer tips on shopping leasing lemon laws insurance and much more Lemon-Aid Used Cars and Trucks 2009-2010 Phil Edmonston,2009-02-16 For the first time in one volume Phil Edmonston Canada s automotive Dr Phil covers all used vehicles packing this guide with insider tips to help the consumer make the safest and cheapest choice possible from cars and trucks of the past 25 years Lemon-Aid Used Cars and Trucks 2010-2011 Phil Edmonston,2010-05-11 The automotive maven and former Member of Parliament might be the most trusted man in Canada an inverse relationship to the people he writes about **The Globe** and

Mail Lemon Aid shows car and truck buyers how to pick the cheapest and most reliable vehicles from the past 30 years of auto production This brand new edition of the bestselling guide contains updated information on secret service bulletins that can save you money Phil describes sales and service scams lists which vehicles are factory goofs and sets out the prices you should pay As Canada s automotive Dr Phil for over 40 years Edmonston pulls no punches His Lemon Aid is more potent and provocative than ever *Lemon-Aid* Phil Edmonston,2005-12 New car and minivan rating guide *Popular Mechanics* ,1996-05 Popular Mechanics inspires instructs and influences readers to help them master the modern world Whether it s practical DIY home improvement tips gadgets and digital technology information on the newest cars or the latest breakthroughs in science PM is the ultimate guide to our high tech lifestyle **Automotive News** ,2005 *Edmunds New Cars & Trucks Buyer's Guide 2004* The Editors at Edmunds.com,2004-01-01 For more than thirty seven years millions of consumers have turned to Edmunds buyer s guide for their shopping needs This format makes it easier for consumers to get the advice and information they need to purchase their next new vehicle Readers benefit from features such as Comprehensive vehicle reviews Easy to use charts that rate competitive vehicles in popular market segments Expanded in depth advice on buying and leasing Editors and consumers ratings Larger photographs Predicted resale values for all models In addition to these features vehicle shoppers can benefit from the best that they ve come to expect from the Edmunds name In depth articles on all new vehicles Crash test ratings from the National Highway Traffic Safety Administration and the Insurance Institute for Highway Safety Warranty information and more **The New York Times Index** ,2007 **International Aerospace Abstracts** ,1997

Immerse yourself in the artistry of words with Crafted by is expressive creation, Discover the Artistry of **Toyota Echo Manual Transmission Removal** . This ebook, presented in a PDF format (Download in PDF: *), is a masterpiece that goes beyond conventional storytelling. Indulge your senses in prose, poetry, and knowledge. Download now to let the beauty of literature and artistry envelop your mind in a unique and expressive way.

<http://www.frostbox.com/data/uploaded-files/fetch.php/Twister%20Trouble%20The%20Magic%20School%20Bus%20Chapter%20Book%205.pdf>

Table of Contents Toyota Echo Manual Transmission Removal

1. Understanding the eBook Toyota Echo Manual Transmission Removal
 - The Rise of Digital Reading Toyota Echo Manual Transmission Removal
 - Advantages of eBooks Over Traditional Books
2. Identifying Toyota Echo Manual Transmission Removal
 - Exploring Different Genres
 - Considering Fiction vs. Non-Fiction
 - Determining Your Reading Goals
3. Choosing the Right eBook Platform
 - Popular eBook Platforms
 - Features to Look for in an Toyota Echo Manual Transmission Removal
 - User-Friendly Interface
4. Exploring eBook Recommendations from Toyota Echo Manual Transmission Removal
 - Personalized Recommendations
 - Toyota Echo Manual Transmission Removal User Reviews and Ratings
 - Toyota Echo Manual Transmission Removal and Bestseller Lists
5. Accessing Toyota Echo Manual Transmission Removal Free and Paid eBooks
 - Toyota Echo Manual Transmission Removal Public Domain eBooks
 - Toyota Echo Manual Transmission Removal eBook Subscription Services

- Toyota Echo Manual Transmission Removal Budget-Friendly Options
- 6. Navigating Toyota Echo Manual Transmission Removal eBook Formats
 - ePub, PDF, MOBI, and More
 - Toyota Echo Manual Transmission Removal Compatibility with Devices
 - Toyota Echo Manual Transmission Removal Enhanced eBook Features
- 7. Enhancing Your Reading Experience
 - Adjustable Fonts and Text Sizes of Toyota Echo Manual Transmission Removal
 - Highlighting and Note-Taking Toyota Echo Manual Transmission Removal
 - Interactive Elements Toyota Echo Manual Transmission Removal
- 8. Staying Engaged with Toyota Echo Manual Transmission Removal
 - Joining Online Reading Communities
 - Participating in Virtual Book Clubs
 - Following Authors and Publishers Toyota Echo Manual Transmission Removal
- 9. Balancing eBooks and Physical Books Toyota Echo Manual Transmission Removal
 - Benefits of a Digital Library
 - Creating a Diverse Reading Collection Toyota Echo Manual Transmission Removal
- 10. Overcoming Reading Challenges
 - Dealing with Digital Eye Strain
 - Minimizing Distractions
 - Managing Screen Time
- 11. Cultivating a Reading Routine Toyota Echo Manual Transmission Removal
 - Setting Reading Goals Toyota Echo Manual Transmission Removal
 - Carving Out Dedicated Reading Time
- 12. Sourcing Reliable Information of Toyota Echo Manual Transmission Removal
 - Fact-Checking eBook Content of Toyota Echo Manual Transmission Removal
 - Distinguishing Credible Sources
- 13. Promoting Lifelong Learning
 - Utilizing eBooks for Skill Development
 - Exploring Educational eBooks
- 14. Embracing eBook Trends

- Integration of Multimedia Elements
- Interactive and Gamified eBooks

Toyota Echo Manual Transmission Removal Introduction

In today's digital age, the availability of Toyota Echo Manual Transmission Removal books and manuals for download has revolutionized the way we access information. Gone are the days of physically flipping through pages and carrying heavy textbooks or manuals. With just a few clicks, we can now access a wealth of knowledge from the comfort of our own homes or on the go. This article will explore the advantages of Toyota Echo Manual Transmission Removal books and manuals for download, along with some popular platforms that offer these resources. One of the significant advantages of Toyota Echo Manual Transmission Removal books and manuals for download is the cost-saving aspect. Traditional books and manuals can be costly, especially if you need to purchase several of them for educational or professional purposes. By accessing Toyota Echo Manual Transmission Removal versions, you eliminate the need to spend money on physical copies. This not only saves you money but also reduces the environmental impact associated with book production and transportation. Furthermore, Toyota Echo Manual Transmission Removal books and manuals for download are incredibly convenient. With just a computer or smartphone and an internet connection, you can access a vast library of resources on any subject imaginable. Whether you're a student looking for textbooks, a professional seeking industry-specific manuals, or someone interested in self-improvement, these digital resources provide an efficient and accessible means of acquiring knowledge. Moreover, PDF books and manuals offer a range of benefits compared to other digital formats. PDF files are designed to retain their formatting regardless of the device used to open them. This ensures that the content appears exactly as intended by the author, with no loss of formatting or missing graphics. Additionally, PDF files can be easily annotated, bookmarked, and searched for specific terms, making them highly practical for studying or referencing. When it comes to accessing Toyota Echo Manual Transmission Removal books and manuals, several platforms offer an extensive collection of resources. One such platform is Project Gutenberg, a nonprofit organization that provides over 60,000 free eBooks. These books are primarily in the public domain, meaning they can be freely distributed and downloaded. Project Gutenberg offers a wide range of classic literature, making it an excellent resource for literature enthusiasts. Another popular platform for Toyota Echo Manual Transmission Removal books and manuals is Open Library. Open Library is an initiative of the Internet Archive, a non-profit organization dedicated to digitizing cultural artifacts and making them accessible to the public. Open Library hosts millions of books, including both public domain works and contemporary titles. It also allows users to borrow digital copies of certain books for a limited period, similar to a library lending system. Additionally, many universities and educational institutions have their own digital libraries that provide free access to PDF books and manuals. These libraries

often offer academic texts, research papers, and technical manuals, making them invaluable resources for students and researchers. Some notable examples include MIT OpenCourseWare, which offers free access to course materials from the Massachusetts Institute of Technology, and the Digital Public Library of America, which provides a vast collection of digitized books and historical documents. In conclusion, Toyota Echo Manual Transmission Removal books and manuals for download have transformed the way we access information. They provide a cost-effective and convenient means of acquiring knowledge, offering the ability to access a vast library of resources at our fingertips. With platforms like Project Gutenberg, Open Library, and various digital libraries offered by educational institutions, we have access to an ever-expanding collection of books and manuals. Whether for educational, professional, or personal purposes, these digital resources serve as valuable tools for continuous learning and self-improvement. So why not take advantage of the vast world of Toyota Echo Manual Transmission Removal books and manuals for download and embark on your journey of knowledge?

FAQs About Toyota Echo Manual Transmission Removal Books

How do I know which eBook platform is the best for me? Finding the best eBook platform depends on your reading preferences and device compatibility. Research different platforms, read user reviews, and explore their features before making a choice. Are free eBooks of good quality? Yes, many reputable platforms offer high-quality free eBooks, including classics and public domain works. However, make sure to verify the source to ensure the eBook credibility. Can I read eBooks without an eReader? Absolutely! Most eBook platforms offer webbased readers or mobile apps that allow you to read eBooks on your computer, tablet, or smartphone. How do I avoid digital eye strain while reading eBooks? To prevent digital eye strain, take regular breaks, adjust the font size and background color, and ensure proper lighting while reading eBooks. What the advantage of interactive eBooks? Interactive eBooks incorporate multimedia elements, quizzes, and activities, enhancing the reader engagement and providing a more immersive learning experience. Toyota Echo Manual Transmission Removal is one of the best book in our library for free trial. We provide copy of Toyota Echo Manual Transmission Removal in digital format, so the resources that you find are reliable. There are also many Ebooks of related with Toyota Echo Manual Transmission Removal. Where to download Toyota Echo Manual Transmission Removal online for free? Are you looking for Toyota Echo Manual Transmission Removal PDF? This is definitely going to save you time and cash in something you should think about. If you trying to find then search around for online. Without a doubt there are numerous these available and many of them have the freedom. However without doubt you receive whatever you purchase. An alternate way to get ideas is always to check another Toyota Echo Manual Transmission Removal. This method for see exactly what may be included and adopt these ideas to your book. This site will almost certainly help you save time and effort, money and stress. If you are

looking for free books then you really should consider finding to assist you try this. Several of Toyota Echo Manual Transmission Removal are for sale to free while some are payable. If you arent sure if the books you would like to download works with for usage along with your computer, it is possible to download free trials. The free guides make it easy for someone to free access online library for download books to your device. You can get free download on free trial for lots of books categories. Our library is the biggest of these that have literally hundreds of thousands of different products categories represented. You will also see that there are specific sites catered to different product types or categories, brands or niches related with Toyota Echo Manual Transmission Removal. So depending on what exactly you are searching, you will be able to choose e books to suit your own need. Need to access completely for Campbell Biology Seventh Edition book? Access Ebook without any digging. And by having access to our ebook online or by storing it on your computer, you have convenient answers with Toyota Echo Manual Transmission Removal To get started finding Toyota Echo Manual Transmission Removal, you are right to find our website which has a comprehensive collection of books online. Our library is the biggest of these that have literally hundreds of thousands of different products represented. You will also see that there are specific sites catered to different categories or niches related with Toyota Echo Manual Transmission Removal So depending on what exactly you are searching, you will be able to choose ebook to suit your own need. Thank you for reading Toyota Echo Manual Transmission Removal. Maybe you have knowledge that, people have search numerous times for their favorite readings like this Toyota Echo Manual Transmission Removal, but end up in harmful downloads. Rather than reading a good book with a cup of coffee in the afternoon, instead they juggled with some harmful bugs inside their laptop. Toyota Echo Manual Transmission Removal is available in our book collection an online access to it is set as public so you can download it instantly. Our digital library spans in multiple locations, allowing you to get the most less latency time to download any of our books like this one. Merely said, Toyota Echo Manual Transmission Removal is universally compatible with any devices to read.

Find Toyota Echo Manual Transmission Removal :

[twister trouble the magic school bus chapter book 5](#)

[tybaf question papers](#)

[types of forces cstephenmurray](#)

tutorial tutorial tutorial tutorial dragonframe user guide

turtle beach dss user guide

[tv guide subscription best price](#)

tv guide for the gold coast

[typhoon my guide 55xl bluetooth](#)

[twisted metal 2 manual](#)

tyre repair kit kmart

tzr 50 parts manual

[tyco electronics manual arbor press](#)

[tweedehands boeken amsterdam](#)

[tv guide sunday 21 december](#)

tv3 new zealand guide

Toyota Echo Manual Transmission Removal :

[summit resources ldoce](#) - Jan 07 2023

web 1 answer key for summit 1 listening case studies on leaving no one behind a companion volume to the development co operation report 2018 may 28 2021 these

listening practice 1 summit 1 listening practice studocu - Jun 12 2023

web answers will vary summit 1 third edition possible answers julie encouraged her daughter to study hard the doctor advised us to eat more fruit mark taught narisa to

[summit 1 work book answer key summit 1 third edition](#) - Aug 22 2021

student s book answer key pdf predation old age scribd - Aug 02 2022

web sm1 book answer summit 1 third edition student s book answer key summit 1 third edition lesson 2 discuss someone s behavior c listen to classify 1 a

[summit 1 work book answer key summit 1 third](#) - Nov 05 2022

web explain your answers 1 that he was gifted 4 that he was passionate 7 that he was moody digital strategies a 1 21 vocabulary describing creative

summit 1 english for today s world google books - Feb 25 2022

web summit 1 units 1 10 review quiz for 12th grade students find other quizzes for english and more on quizizz for free

[summit 1 2nd edition workbook answer key pdf scribd](#) - Mar 09 2023

web summit 1 work book answer key 1 read online for free summit 1a work book answer summit 1a work book answer open navigation menu close suggestions

[472306339 book summit 1 third edition pdf studocu](#) - Apr 29 2022

web dec 6 2016 summit 1 english for today s world joan m saslow allen ascher pearson education dec 6 2016 english language 176 pages with its fresh new look the third

sm2 answer anh summit 2 third edition student s book - Jan 27 2022

web its hence no question easy and in view of that fats isnt it you have to favor to in this appearance myenglishlab summit 1 printed access code joan saslow 2012 01

book summit 1 third edition pdf pdf grammar scribd - Sep 03 2022

web unit 01 workbook ak summit 1 answer key free download as pdf file pdf text file txt or read online for free unit 01 workbook ak summit 1 answer key

summit 1 third edition student book answer key answers for - May 31 2022

web jan 31 2022 summit 1 second edition audio listening if you are a language learner and want to improve your english language skills summit can be the best option for you

politics latest shadow home secretary faces questions as labour - Sep 22 2021

sm1 book answer summit 1 third edition student s - Jul 13 2023

web listening practice 1 test listening university trường Đại học fpt course summit 1 ent403 999 documents students shared 1239 documents in this course academic

summit 1 liveworksheets com - Oct 04 2022

web 1 leo is more of a pessimist nora is more of a realist 2 answers will vary lesson 1 describe your personality b classify the vocabulary are always positive polite punctual

summit 1 ent403 fpt studocu - Apr 10 2023

web workbook answer key unit 1 note in communicative exercises where several answers are possible this answer key contains some examples of correct answers not all

summit 1 work book answer key studocu - May 11 2023

web studying summit 1 ent403 at trường Đại học fpt on studocu you will find 332 lecture notes 247 practice materials 170 practical and much more for summit 1 fpt

answer key to listening strategies unit 1 page 10 listening for - Aug 14 2023

web summit 1 1 answer key to listening strategies unit 1 page 10 listening for key words and phrases answers will vary students should justify their choices unit 2 page 22

summit 1 units 1 10 review 91 plays quizizz - Dec 26 2021

web summit 1 speaking topics free download as word doc doc pdf file pdf text file txt or read online for free download the

document download the document open

summit 1 second edition audio listening cs learning - Mar 29 2022

web b listen to activate parts of speech 1 courageous 2 bravely 3 willingness 4 heroic 5 courage c listen for details 1 b 2 b 3 b 4 b 5 a d listen to retell a story answers

answer key for summit 1 listening - Dec 06 2022

web id 2731830 language english school subject english as a second language esl grade level uni age 18 main content listening other contents lesson 4 add to my

listening answer key summit 1b makeover ixiacom com - Nov 24 2021

web sep 15 2023 yvette cooper is appearing live on sky news as labour announces plans it says will end the use of hotels for asylum seekers and clear the asylum cases backlog

summit 1 work book answer key pdf scribd - Feb 08 2023

web to download an audio file right click on the audio icon or download audio link and select save link as or save target as go to summit homepage summit 1 summit 2

summit 1 speaking topics pdf communication scribd - Oct 24 2021

web summit 1 work book answer key summit 1 third edition workbook answer key note in communicative studocu it s just a matter of time you ve got to roll with the punches

unit 01 workbook ak summit 1 answer key pdf scribd - Jul 01 2022

web b 1 09listen for main ideas listen write the problem discussed in each conversation conversation 1 conversation 2 conversation 3 c 1 10listen for details listen

download epee 2 5 the new paradigm revised and augmented - Jan 29 2022

web bookspublic com 4805312319 read more about paradigm fencing johan olympic shipping and edition

epee 2 5 the new paradigm revised and augmented by johan - Sep 05 2022

web epee 2 5 the new paradigm revised and augmented by johan harmenberg 2014 10 26 0783324867220 amazon com books currently unavailable we don t know when or if this item will be back in stock see clubs

epee 2 5 the new paradigm revised and augmented - Aug 04 2022

web oct 26 2014 johan harmenberg revolutionized epee fencing when he pioneered the new fencing paradigm that lets a fencer neutralize his opponent s superior technique in this new expanded edition of epee 2 0 he hears comments from top

epee 2 5 the new paradigm revised and augmented - Dec 28 2021

web oct 26 2014 book overview johan harmenberg revolutionized epee fencing when he pioneered the new fencing paradigm that lets a fencer neutralize his opponent s superior technique in this new expanded edition of epee 2 0 he hears

comments from top competitors and gives his responses

epee 2 5 the new paradigm revised and augmented - Aug 16 2023

web epee 2 5 the new paradigm revised and augmented harmenberg johan amazon com tr kitap

epee 2 5 the new paradigm revised and augmented - Jul 15 2023

web oct 26 2014 epee 2 5 the new paradigm revised and augmented schmitt arnd boisse philippe mazzoni angelo amazon in books

epee 2 5 the new paradigm revised and augmented - Jan 09 2023

web buy epee 2 5 the new paradigm revised and augmented paperback at walmart com

epee 2 5 the new paradigm revised and augmented - Mar 11 2023

web oct 26 2014 buy epee 2 5 the new paradigm revised and augmented by harmenberg johan schmitt arnd boisse philippe mazzoni angelo vaggoe bjorne pingree geoff isbn 9780985444181 from amazon s book store everyday low prices and free delivery on eligible orders

epee 2 5 the new paradigm revised and augmented by johan - Oct 06 2022

web booktopia has epee 2 5 the new paradigm revised and augmented by johan harmenberg buy a discounted paperback of epee 2 5 online from australia s leading online bookstore

epee 2 5 the new paradigm revised and augmented - Jun 14 2023

web oct 26 2014 epee 2 5 the new paradigm revised and augmented harmenberg johan schmitt arnd boisse philippe mazzoni angelo vaggoe bjorne pingree geoff 9780985444181 books amazon ca

epee 2 5 the new paradigm revised and augmented thriftbooks - Feb 27 2022

web nearly thirty years later these broken adults are dragged back to discover the game isn t finished with them yet kieron gillen the wicked the divine and stephanie hans journey into mystery s award winning critical hit series is collected in a single beautiful oversized hardcover volume collects die volumes 1 4 issues 1 20

epee 2 5 the new paradigm revised and augmented booksrun - May 01 2022

web sell buy or rent epee 2 5 the new paradigm revised and augmented 9780985444181 0985444185 we buy used or new for best buyback price with free shipping and offer great deals for buyers sell epee 2 5 the new paradigm revised and

epee 2 5 the new paradigm revised and augmented by - Feb 10 2023

web find many great new used options and get the best deals for epee 2 5 the new paradigm revised and augmented by johan harmenberg 2014 trade paperback at the best online prices at ebay free shipping for many products

epee 2 5 the new paradigm revised and augmented tapa - Jun 02 2022

web epee 2 5 the new paradigm revised and augmented harmenberg johan schmitt arnd boisse philippe mazzoni angelo

vaggoe bjorne pingree geoff amazon es libros

[download epee 2 5 the new paradigm revised and augmented](#) - Apr 12 2023

web jun 13 2020 book description johan harmenberg revolutionized epee fencing when he pioneered the new fencing paradigm that lets a fencer neutralize his opponent s superior technique in this new expanded edition of epee 2 0 he hears comments from top competitors and gives his responses

epee 2 5 the new paradigm revised and augmented - Mar 31 2022

web oct 26 2014 epee 2 5 the new paradigm revised and augmented author johan harmenberg arnd schmitt contributor philippe boisse contributor format paperback publish date oct 26 2014 isbn 10 0985444185 isbn 13 9780985444181 list price 29 95 add to wish list link to this book add to bookbag sell this book buy it at

epee 2 5 the new paradigm revised and augmented taschenbuch amazon de - Nov 07 2022

web epee 2 5 the new paradigm revised and augmented harmenberg johan schmitt arnd boisse philippe mazzoni angelo vaggoe bjorne pingree geoff isbn 9780985444181 kostenloser versand für alle bücher

epee 2 5 the new paradigm revised and augmented by johan - Dec 08 2022

web find many great new used options and get the best deals for epee 2 5 the new paradigm revised and augmented by johan harmenberg paperback softback 2014 at the best online prices at ebay free shipping for many products

epee 2 5 the new paradigm revised and augmented - Jul 03 2022

web isbn 10 0985444185 isbn 13 9780985444181 publisher ska swordplay books edition 1 no of pages 228 format paperback

epee 2 5 the new paradigm revised and augmented - May 13 2023

web johan harmenberg revolutionized epee fencing when he pioneered the new fencing paradigm that lets a fencer neutralize his opponent s superior technique in this new expanded edition of epee 2 0 he hears comments

badminton spielregeln 2012 2013 pdf pdf eshraqgroup com - Jul 03 2022

web rezeptionsmotive der zuschauer anhand von sechs sportarten badminton beach volleyball biathlon dressurreiten fußball und moderner fünfkampf zeigt diese studie welche strategien und maßnahmen seit 1984 angewandt wurden um eine anpassung des sports an die tv logik zu erzielen methodisch

badmintonspielregeln20122013 pdf deutscher badminton - Jun 02 2022

web jun 27 2023 badminton spielregeln 2012 2013 deutscher badminton verband 2012 title badmintonspielregeln20122013 pdf deutscher badminton verband full pdf created date

badminton oyun kuralları badminton nedir nasıl ve kaç kişiyle - Jan 09 2023

web mar 28 2023 haberler yaşam haberleri badminton oyun kuralları badminton nedir nasıl ve kaç kişiyle oynanır giriş tarihi 28 3 2023 16 47 son güncelleme 28 3 2023 16 47

badminton spielregeln 2012 2013 by deutscher badminton - Sep 05 2022

web badminton spielregeln 2012 2013 by deutscher badminton verband e v badminton spielregeln 2012 2013 by deutscher badminton verband e v list of 2012 summer olympics medal winners 2012 all england super series premier changes in the game characteristics of a badminton match tournaments tournamentsoftware yonex

badminton regeln die badminton spielregeln badmintonregeln - Feb 10 2023

web auf den folgenden seiten kannst du dich in kurzform über die aktuellen badminton spielregeln informieren wie sieht das spielfeld aus wo wird im einzel und im doppel der aufschlag gemacht wie wird gezählt wann werden die seiten gewechselt welche fehler kann man beim spiel machen oder wie muss ein badmintonschläger besaitet sein

badminton spielregeln 2012 2013 pdf pdf - Feb 27 2022

web introduction badminton spielregeln 2012 2013 pdf pdf philosophical issues realism and relativism ernest sosa 2003 01 17 this volume gathers papers by many of the best known philosophers now at work on issues of

badminton satzung ordnungen spielregeln 2011 2012 pdf copy - Jan 29 2022

web badminton satzung ordnungen spielregeln 2012 2013 deutscher badminton verband e v 2012 09 hitler s african victims raffael scheck 2006 04 03 publisher description be dynamic acts 1 12 warren w wiersbe 2012 12 10 in his first of two books covering the book of acts be dynamic focuses on peter s ministry mostly in israel and centered in

badminton oyun bilgileri ve kuralları ders ve çalışma notu - Dec 08 2022

web badminton oyun bilgileri ve kuralları mİgs 1 maç tek erkek 1 maç tek erkek tek kız not bir oyuncu 1 tek 1 çift maçlarda oynayabilir 3 maça çıkamaz takım kız takımı 4 erkek takımı 4 mİgs karma 3 kız 3 erkek oyuncudan oluşur sayılar maçlar 3 set üzerinden oynanır 3 ün 2 sini alan galiptir

badminton spielregeln 2011 2012 by deutscher badminton - Mar 31 2022

web lee chong wei profile bwf badminton badminton spielregeln 2012 2013 9783898997768 changes in the game characteristics of a badminton match nitin server bertolotto com 2 26 badminton spielregeln 2011 2012 by deutscher badminton verband e v s arora business head pune 7 aces premier

genel bilgiler ve tarihçe türkİye badmİnton - Apr 12 2023

web türkiye de badminton türkiye badminton federasyonu 31 mayıs 1991 tarihinde kurulmuştur 3 kasım 1991 tarihinde 104 Üye sıfatıyla uluslararası badminton federasyonu tarafından tam üyeliğe kabul edilmiştir türkiye badminton federasyonu nun kurucu başkanı ve ilk başkanı İrfan yıldırım dır

badminton spielregeln 2012 2013 by deutscher badminton - May 13 2023

web valhúsaskóli 2012 2013 badmintonval olympics badminton scandal rocks china the daily beast die badminton spielregeln badminton spielregeln 2012 2013 9783898997768 rapport financier 2012 2013 badminton québec holdturnering

badmintonplayer parupalli kashyap 2012 2013 lu inská liga

badminton spielregeln 2012 2013 - Aug 16 2023

web dieses taschenbuch enthält alle informationen zu den spielregeln im badminton und richtet sich an alle interessierten spieler trainer schiedsrichter und funktionäre inhalt spielfeld und ausstattung spielball balltest und geschwindigkeit schläger zustimmung für spezielle ausstattungen wahl punktsystem zählweise wechsel der

badminton nedir nasıl oynanır badminton oyunu kuralları milliyet - Nov 07 2022

web jan 19 2021 badminton nedir badminton oyununda iki kişi veya ikişer kişilik gruplar karşı karşıya geçer raket ve tüylü bir top eşliğinde oynanan bir spordur file ile ortadan ikiye bölünmüş

download badminton spielregeln 2012 2013 deutscher badminton - Oct 06 2022

web ebook d badminton spielregeln 2012 2013 gratis epub bücher badminton spielregeln 2012 2013 kostenlos ebook

download badminton spielregeln

badminton spielregeln 2012 2013 by deutscher badminton - Dec 28 2021

web april 12th 2020 badminton spielregeln 2012 2013 on free shipping on qualifying offers badminton spielregeln 2012 2013 olympic charter amp other official ioc documents downloads

badminton spielregeln 2012 2013 pdf ammonportfolio com - Aug 04 2022

web mar 19 2023 complete not discover the statement badminton spielregeln 2012 2013 pdf that you are looking for it will no question squander the time however below behind you visit this web page it will be appropriately definitely simple to get as capably as download guide badminton spielregeln 2012 2013 pdf it will not say yes many grow old as we

badminton ausgabe 2012 2013 satzung ordnungen spielregeln - Jul 15 2023

web klappentext inhalt organigramm im satzungswerk verwendete abkürzungen satzung anti doping code adc geschäftsordnung go rechtsordnung ro finanzordnung fo ehrenordnung eo trainerordnung tro spielordnung spo bundesligaordnung blo jugendordnung jo jugendspielordnung jsपो schiedsrichterordnung sro

badminton spielregeln 2013 2014 amazon com tr - Mar 11 2023

web badminton spielregeln 2013 2014 deutscher badminton verband e v amazon com tr kitap

badminton spielregeln 2012 2013 help environment harvard edu - May 01 2022

web jun 18 2023 badminton spielregeln 2012 2013 as you such as by searching the title publisher or authors of guide you in point of fact want you can discover them rapidly in the house workplace or perhaps in your method can be every best area within net connections if you mean to download and install the badminton spielregeln 2012 2013 it is

badminton spielregeln 2012 2013 by deutscher badminton - Jun 14 2023

web aug 16 2023 badminton 2012 2013 badminton jano tíkovi spielregeln deutscher badminton verband innsbruck 2012

youth olympic games yog results amp video lisa robin kelly past results connecticut masters games list of