

OBSERVATION:

F (HZ)	V_o	Log f	V_o/V_{in}	G_{dB}

CIRCUIT:

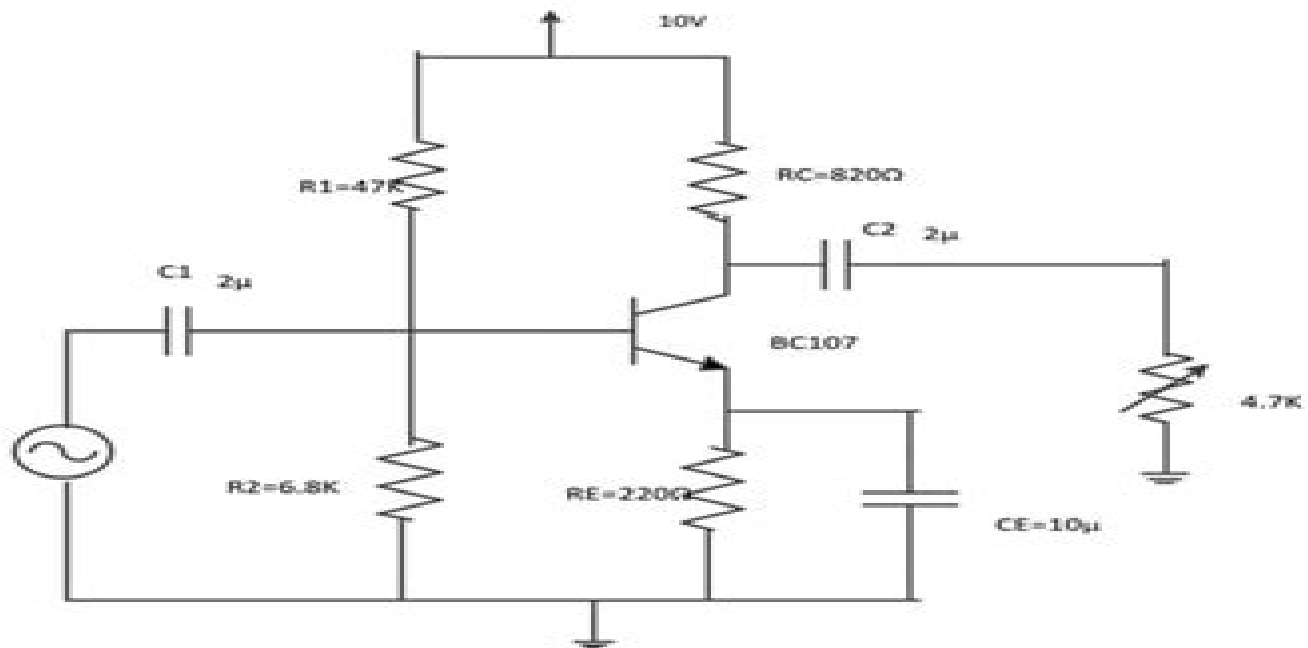

Vtu Analog Electronics Laboratory Manual

L. K. MAHESHWARI, M. M. S. ANAND



Vtu Analog Electronics Laboratory Manual:

Analog Circuits and its Simulation in PSPICE Dr A Chrispin Jiji, 2021-06-23 This book is intended to support the students of undergraduate engineering in the related fields of Electronics and Communication Engineering as well as Telecommunication Engineering courses for practicing laboratory experiments It gives relevant information on the basic understanding of circuit configurations and connectivity of BJT and FET Amplifiers and Study of frequency response It presents the design and test of Analog circuits using OPAMPs understand the feedback configurations of transistor and OPAMP circuits and the use of circuit simulation for the analysis of electronic circuits using PSPICE It also provides various methods and techniques for conducting the experiment Clear circuit diagrams and proper calculations have been provided for all the experiments and simple language has been used throughout the book for better understanding of the concepts for the students

Analog Integrated Circuits with PSPICE Dr A Chrispin Jiji, 2021-12-21 This book is intended to support the students of undergraduate engineering in the related fields of Electronics and Communication Engineering as well as Telecommunication Engineering courses for practicing laboratory experiments It gives relevant information on the basic understanding of circuit configurations and connectivity of BJT and FET Amplifiers and Study of frequency response It presents the design and test of Analog Integrated circuits using OPAMPs understand the feedback configurations of transistor and OPAMP circuits and the use of circuit simulation for the analysis of electronic circuits using PSPICE It also provides various methods and techniques for conducting the experiment Clear circuit diagrams and proper calculations have been provided for all the experiments and simple language has been used throughout the book for better understanding of the concepts for the students

Electronic Circuits Analysis & its Simulation with PSPICE Dr. A. Chrispin Jiji, J. Jesy Janet Kumari, P. Revathi , 2023-05-31 This book is intended to support the students of undergraduate engineering in the related fields of Electronics and Communication Engineering as well as Telecommunication Engineering courses for practicing laboratory experiments It gives relevant information on the basic understanding of circuit configurations and connectivity of BJT and FET Amplifiers and Study of frequency response It presents the design and test of analog circuits using OPAMPs understand the feedback configurations of transistor and OPAMP circuits and the use of circuit simulation for the analysis of electronic circuits using PSPICE It also provides various methods and techniques for conducting the experiment Clear circuit diagrams and proper calculations have been provided for all the experiments and simple language has been used throughout the book for better understanding of the concepts for the students

Laboratory Manual for Introductory Electronics Experiments L. K. Maheshwari, M. M. S. Anand, 1979

Analog Electronic Circuits and Systems Gary E. Ford, Carl M. Arft, 2006-06-05

Analog Electronics in a Digital Setting Gerald E. Williams, 1988-01-01

LABORATORY EXPERIMENTS AND PSPICE SIMULATIONS IN ANALOG ELECTRONICS L. K. MAHESHWARI, M. M. S. ANAND, 2006-01-01 This laboratory manual for students of Electronics Electrical Instrumentation Communication and

Computer engineering disciplines has been prepared in the form of a standalone text offering the necessary theory and circuit diagrams with each experiment Procedures for setting up the circuits and measuring and evaluating their performance are designed to support the material of the authors book Analog Electronics also published by PHI Learning There are twenty five experiments The experiments cover the basic transistor circuits the linear op amp circuits the active filters the non linear op amp circuits the signal generators the voltage regulators the power amplifiers the high frequency amplifiers and the data converters In addition to the hands on experiments using traditional test equipment and components this manual describes the simulation of circuits using PSPICE as well For PSPICE simulation any available standard SPICE software may be used including the latest version OrCAD V10 Demo software This feature allows the instructor to adopt a single laboratory manual for both types of experiments

ELECTRONICS LAB MANUAL Volume I, FIFTH EDITION
NAVAS, K. A.,2015-09-11 This lab manual is intended to support the students of undergraduate engineering in the related fields of electronics engineering for practicing laboratory experiments It will also be useful to the undergraduate students of electrical science branches of engineering and applied science This book begins with an introduction to the electronic components and equipment and the experiments for electronics workshop Further it covers experiments for basic electronics lab electronic circuits lab and digital electronics lab A separate chapter is devoted to the simulation of electronics experiments using PSpice Each experiment has aim components and equipment required theory circuit diagram tables graphs alternate circuits answered questions and troubleshooting techniques Answered viva voce questions and solved examination questions given at the end of each experiment will be very helpful for the students The purpose of the experiments described here is to acquaint the students with Analog and digital devices Design of circuits Instruments and procedures for electronic test and measurement

Commerce Business Daily ,2000-06 *Analog Electronic Circuits Laboratory Manual* Farzin Asadi,2023-04-06 This is a book for a lab course meant to accompany or follow any standard course in electronic circuit analysis It has been written for sophomore or junior electrical and computer engineering students either concurrently with their electronic circuit analysis class or following that class This book is appropriate for non majors such as students in other branches of engineering and in physics for which electronic circuits is a required course or elective and for whom a working knowledge of electronic circuits is desirable This book has the following objectives 1 To support verify and supplement the theory to show the relations and differences between theory and practice 2 To teach measurement techniques 3 To convince students that what they are taught in their lecture classes is real and useful 4 To help make students tinkerers and make them used to asking what if questions

Experiments in Analog and Digital Electronics
Thomas Brewer,1997-01-01 **Experiments in Analog and Digital Electronics** Thomas E. Brewer,2004-07-09

Solid-state Analog and Digital Electronics Laboratory Manual Thomas D. Strickler,1982 *Lab Manual for Electronics* Martin Feldman,2001-11 The emphasis is first on understanding the characteristics of basic circuits including

resistors capacitors diodes and bipolar and field effect transistors The readers then use this understanding to construct more complex circuits such as power supplies differential amplifiers tuned circuit amplifiers a transistor curve tracer and a digital voltmeter In addition readers are exposed to special topics of current interest such as the propagation and detection of signals through fiber optics the use of Van der Pauw patterns for precise linewidth measurements and high gain amplifiers based on active loads KEY TOPICS Chapter topics include Thevenin s Theorem Resistive Voltage Division Silicon Diodes Resistor Capacitor Circuits Half Wave Rectifiers DC Power Supplies Diode Applications Bipolar Transistors Field Effect Transistors Characterization of Op Amp Circuits Transistor Curve Tracer Introduction to PSPICE and AC Voltage Dividers Characterization and Design of Emitter and Source Followers Characterization and Design of an AC Variable Gain Amplifier Design of Test Circuits for BJT s and FET s and Design of FET Ring Oscillators Design and Characterization of Emitter Coupled Transistor Pairs Tuned Amplifier and Oscillator Design of Am Radio Frequency Transmitter and Receiver Design of Oscillators Using Op Amps Current Mirrors and Active Loads Sheet Resistance Design of Analog Fiber Optic Transmission System Digital Voltmeter

Experiments in Analog Electronics Wayne Hope,1995-01-01 *Analog Electronics* Gerald Earl Williams,1996 This comprehensive electronics text designed for electronics technology majors provides a real world orientation for future working technicians Numerous carefully designed drawings and photos are included throughout to insure that each concept is fully understood Includes the latest analog integrated circuits Digital Applications show students the importance of digital in the analog world All discussions are interrelated by common theme of feedback Specially designed transistor circuit analysis flow charts simplify basic transistor concepts Manageable for one semester Accompanied by superior lab and instructor s manuals and a unique Student Survival Guide for Analog Electronics by the text author ALSO AVAILABLE Laboratory Manual ISBN 0 314 04677 1 INSTRUCTOR SUPPLEMENTS CALL CUSTOMER SUPPORT TO ORDER Instructor s Guide ISBN 0 314 05522 3 Transparency Masters ISBN 0 314 04925 8 Keywords Electronic Devices

Experiments in Analog and Digital Electronics Brewer,1998-01-01 *Analogue Electronics Analogue Systems (G)* Canberra College of Advanced Education,1987 [Introduction to Analog and Digital Circuits Lab Manual](#) Brian DEAN,2018-08-13 [Laboratory Manual for Electronics via Waveform Analysis](#) Edwin C. Craig,2012-12-06 To the Instructor The purpose of this laboratory manual is not just to help students to set up electronic circuits that function as they should The important thing is the electronic concepts that the student learns in the process of setting up and studying these circuits Quite often a student learns more electronics when he has to trouble shoot a circuit than when the circuit performs as it should when first built It is unlikely that any students would be able to complete all of these experiments in one semester The author believes that all students should have laboratory experiences with power supplies amplifiers oscillators and integrated circuits Additional laboratory experiments should be determined by the instructor Therefore you can choose those that you want done Some students are more efficient in the laboratory than others Therefore some would be able to complete

more experiments in a semester than others. Also many of these experiments cannot be completed in one two hour laboratory period. If space is available the circuits could be left intact from one period to the next. Or you might want to select steps in an experiment that you want to delete. Neither the values of the components or the magnitudes of the power supplies as given in the instructions are critical. Therefore you could in most cases change them if the ones recommended are not available.

Unveiling the Magic of Words: A Overview of "**Vtu Analog Electronics Laboratory Manual**"

In a global defined by information and interconnectivity, the enchanting power of words has acquired unparalleled significance. Their capability to kindle emotions, provoke contemplation, and ignite transformative change is actually awe-inspiring. Enter the realm of "**Vtu Analog Electronics Laboratory Manual**," a mesmerizing literary masterpiece penned by a distinguished author, guiding readers on a profound journey to unravel the secrets and potential hidden within every word. In this critique, we shall delve into the book is central themes, examine its distinctive writing style, and assess its profound impact on the souls of its readers.

<http://www.frostbox.com/public/Resources/fetch.php/thyssenkrupp%20lift%20installation%20manual.pdf>

Table of Contents Vtu Analog Electronics Laboratory Manual

1. Understanding the eBook Vtu Analog Electronics Laboratory Manual
 - The Rise of Digital Reading Vtu Analog Electronics Laboratory Manual
 - Advantages of eBooks Over Traditional Books
2. Identifying Vtu Analog Electronics Laboratory Manual
 - Exploring Different Genres
 - Considering Fiction vs. Non-Fiction
 - Determining Your Reading Goals
3. Choosing the Right eBook Platform
 - Popular eBook Platforms
 - Features to Look for in an Vtu Analog Electronics Laboratory Manual
 - User-Friendly Interface
4. Exploring eBook Recommendations from Vtu Analog Electronics Laboratory Manual
 - Personalized Recommendations
 - Vtu Analog Electronics Laboratory Manual User Reviews and Ratings
 - Vtu Analog Electronics Laboratory Manual and Bestseller Lists

5. Accessing Vtu Analog Electronics Laboratory Manual Free and Paid eBooks
 - Vtu Analog Electronics Laboratory Manual Public Domain eBooks
 - Vtu Analog Electronics Laboratory Manual eBook Subscription Services
 - Vtu Analog Electronics Laboratory Manual Budget-Friendly Options
6. Navigating Vtu Analog Electronics Laboratory Manual eBook Formats
 - ePub, PDF, MOBI, and More
 - Vtu Analog Electronics Laboratory Manual Compatibility with Devices
 - Vtu Analog Electronics Laboratory Manual Enhanced eBook Features
7. Enhancing Your Reading Experience
 - Adjustable Fonts and Text Sizes of Vtu Analog Electronics Laboratory Manual
 - Highlighting and Note-Taking Vtu Analog Electronics Laboratory Manual
 - Interactive Elements Vtu Analog Electronics Laboratory Manual
8. Staying Engaged with Vtu Analog Electronics Laboratory Manual
 - Joining Online Reading Communities
 - Participating in Virtual Book Clubs
 - Following Authors and Publishers Vtu Analog Electronics Laboratory Manual
9. Balancing eBooks and Physical Books Vtu Analog Electronics Laboratory Manual
 - Benefits of a Digital Library
 - Creating a Diverse Reading Collection Vtu Analog Electronics Laboratory Manual
10. Overcoming Reading Challenges
 - Dealing with Digital Eye Strain
 - Minimizing Distractions
 - Managing Screen Time
11. Cultivating a Reading Routine Vtu Analog Electronics Laboratory Manual
 - Setting Reading Goals Vtu Analog Electronics Laboratory Manual
 - Carving Out Dedicated Reading Time
12. Sourcing Reliable Information of Vtu Analog Electronics Laboratory Manual
 - Fact-Checking eBook Content of Vtu Analog Electronics Laboratory Manual
 - Distinguishing Credible Sources
13. Promoting Lifelong Learning

- Utilizing eBooks for Skill Development
 - Exploring Educational eBooks
14. Embracing eBook Trends
- Integration of Multimedia Elements
 - Interactive and Gamified eBooks

Vtu Analog Electronics Laboratory Manual Introduction

In the digital age, access to information has become easier than ever before. The ability to download Vtu Analog Electronics Laboratory Manual has revolutionized the way we consume written content. Whether you are a student looking for course material, an avid reader searching for your next favorite book, or a professional seeking research papers, the option to download Vtu Analog Electronics Laboratory Manual has opened up a world of possibilities. Downloading Vtu Analog Electronics Laboratory Manual provides numerous advantages over physical copies of books and documents. Firstly, it is incredibly convenient. Gone are the days of carrying around heavy textbooks or bulky folders filled with papers. With the click of a button, you can gain immediate access to valuable resources on any device. This convenience allows for efficient studying, researching, and reading on the go. Moreover, the cost-effective nature of downloading Vtu Analog Electronics Laboratory Manual has democratized knowledge. Traditional books and academic journals can be expensive, making it difficult for individuals with limited financial resources to access information. By offering free PDF downloads, publishers and authors are enabling a wider audience to benefit from their work. This inclusivity promotes equal opportunities for learning and personal growth. There are numerous websites and platforms where individuals can download Vtu Analog Electronics Laboratory Manual. These websites range from academic databases offering research papers and journals to online libraries with an expansive collection of books from various genres. Many authors and publishers also upload their work to specific websites, granting readers access to their content without any charge. These platforms not only provide access to existing literature but also serve as an excellent platform for undiscovered authors to share their work with the world. However, it is essential to be cautious while downloading Vtu Analog Electronics Laboratory Manual. Some websites may offer pirated or illegally obtained copies of copyrighted material. Engaging in such activities not only violates copyright laws but also undermines the efforts of authors, publishers, and researchers. To ensure ethical downloading, it is advisable to utilize reputable websites that prioritize the legal distribution of content. When downloading Vtu Analog Electronics Laboratory Manual, users should also consider the potential security risks associated with online platforms. Malicious actors may exploit vulnerabilities in unprotected websites to distribute malware or steal personal information. To protect themselves, individuals should ensure their devices have reliable antivirus software installed and validate the legitimacy of the websites

they are downloading from. In conclusion, the ability to download Vtu Analog Electronics Laboratory Manual has transformed the way we access information. With the convenience, cost-effectiveness, and accessibility it offers, free PDF downloads have become a popular choice for students, researchers, and book lovers worldwide. However, it is crucial to engage in ethical downloading practices and prioritize personal security when utilizing online platforms. By doing so, individuals can make the most of the vast array of free PDF resources available and embark on a journey of continuous learning and intellectual growth.

FAQs About Vtu Analog Electronics Laboratory Manual Books

What is a Vtu Analog Electronics Laboratory Manual PDF? A PDF (Portable Document Format) is a file format developed by Adobe that preserves the layout and formatting of a document, regardless of the software, hardware, or operating system used to view or print it. **How do I create a Vtu Analog Electronics Laboratory Manual PDF?** There are several ways to create a PDF: Use software like Adobe Acrobat, Microsoft Word, or Google Docs, which often have built-in PDF creation tools. Print to PDF: Many applications and operating systems have a "Print to PDF" option that allows you to save a document as a PDF file instead of printing it on paper. Online converters: There are various online tools that can convert different file types to PDF. **How do I edit a Vtu Analog Electronics Laboratory Manual PDF?** Editing a PDF can be done with software like Adobe Acrobat, which allows direct editing of text, images, and other elements within the PDF. Some free tools, like PDFescape or Smallpdf, also offer basic editing capabilities. **How do I convert a Vtu Analog Electronics Laboratory Manual PDF to another file format?** There are multiple ways to convert a PDF to another format: Use online converters like Smallpdf, Zamzar, or Adobe Acrobats export feature to convert PDFs to formats like Word, Excel, JPEG, etc. Software like Adobe Acrobat, Microsoft Word, or other PDF editors may have options to export or save PDFs in different formats. **How do I password-protect a Vtu Analog Electronics Laboratory Manual PDF?** Most PDF editing software allows you to add password protection. In Adobe Acrobat, for instance, you can go to "File" -> "Properties" -> "Security" to set a password to restrict access or editing capabilities. Are there any free alternatives to Adobe Acrobat for working with PDFs? Yes, there are many free alternatives for working with PDFs, such as: LibreOffice: Offers PDF editing features. PDFsam: Allows splitting, merging, and editing PDFs. Foxit Reader: Provides basic PDF viewing and editing capabilities. How do I compress a PDF file? You can use online tools like Smallpdf, ILovePDF, or desktop software like Adobe Acrobat to compress PDF files without significant quality loss. Compression reduces the file size, making it easier to share and download. Can I fill out forms in a PDF file? Yes, most PDF viewers/editors like Adobe Acrobat, Preview (on Mac), or various online tools allow you to fill out forms in PDF files by selecting text fields and entering information. Are there any

restrictions when working with PDFs? Some PDFs might have restrictions set by their creator, such as password protection, editing restrictions, or print restrictions. Breaking these restrictions might require specific software or tools, which may or may not be legal depending on the circumstances and local laws.

Find Vtu Analog Electronics Laboratory Manual :

thyssenkrupp lift installation manual

thutong examination papers

~~three tier words and common core standards~~

~~three billy goats gruff costume template~~

thomas calculus 12th edition chapter 1solution

ti86 calculator manual

~~thomson meo manual~~

throttle cable honda gx160 service repair manual

thousand years christina perri

threshold autoregressive models in eviews

thorns bondmate zarronian warriors book english edition

three phase converter wiring diagram

tickling the english

those damn butlers a short story

thutong accounting grade 1november

Vtu Analog Electronics Laboratory Manual :

Life's Healing Choices Revised and Updated John Baker, a former pastor at Saddleback Church, based this book on the eight steps to spiritual freedom (admitting need, getting help, letting go, coming ... Life's Healing Choices Revised and Updated Through making each of these choices, you too will find God's pathway to wholeness, growth, spiritual maturity, happiness, and healing. Life's Healing Choices: Freedom from Your... by Baker, John Book overview ... With a foreword by Rick Warren, author of The Purpose Driven Life, this life-changing book helps you find true happiness—if you choose to accept ... Life's Healing Choices - Learn - Shop Life's Healing Choices · Life's Healing Choices Revised and Updated. Life's Healing Choices Small Group Study Guide Includes 8 study sessions, led by the Life's Healing Choices Small Group DVD that takes you step-

by-step through the recovery and self-discovery process. Life's Healing Choices: Freedom from Your Hurts, Hang- ... Read 84 reviews from the world's largest community for readers. LIFE HAPPENS. Happiness and Healing are yours for the choosing. We've all been hurt by ot... Life's Healing Choices Revised And Updated: Freedom ... The road to spiritual maturity is paved with life-changing decisions. Travel toward wholeness, growth, and freedom by following Jesus' signposts along the ... Life's Healing Choices Small Groups Life's Healing Choices Small Groups ... All leaders are learners. As soon as you stop learning, you stop leading. The Ministry Toolbox is designed to help you ... Life's Healing Choices | LIFE HAPPENS - Happiness and Healing are yours for the choosing. We've all been hurt by other people, we've hurt ourselves, and we've hurt others. And as a ... Robinson Crusoe | Daniel Defoe, Michael Shinagel The Second Edition of the Norton Critical Edition of Robinson Crusoe is based on the Shakespeare Head Press reprint of the first edition copy in the British ... Robinson Crusoe (Norton Critical Editions) ... Book details · Print length. 448 pages · Language. English · Publisher. W. W. Norton & Company · Publication date. December 17, 1993 · Dimensions. 5.1 x 1 x 8.4 ... Robinson Crusoe (Norton Critical Editions) Rent textbook Robinson Crusoe (Norton Critical Editions) by Defoe, Daniel - 9780393964523. Price: \$11.62. Robinson Crusoe (Norton Critical Editions): Defoe, Daniel Book details · Language. English · Publisher. Signet Classic · Publication date. January 1, 1980 · Dimensions. 5 x 0.98 x 7.99 inches · ISBN-10. 0393092313. Robinson Crusoe (Norton Critical Editions) Paperback. Published 12/1980 by W W Norton & Co Ltd. Sections: ISBN 9780393092318. List Price: \$9.95. Our Price: \$7.50 (Save 25%). Used — \$7.50. Add to cart Robinson Crusoe (Norton Critical Editions) The Second Edition of the Norton Critical Edition of Robinson Crusoe is based on the Shakespeare Head Press reprint of the first edition copy in the British ... Robinson Crusoe (Norton Critical Editions) Robinson Crusoe (Norton Critical Editions) by Defoe, Daniel - ISBN 10: 0393964523 - ISBN 13: 9780393964523 - W. W. Norton & Company - 1993 - Softcover. Robinson Crusoe (A Norton critical edition) Robinson Crusoe (A Norton critical edition) by Defoe, Daniel - ISBN 10: 0393044076 - ISBN 13: 9780393044072 - Norton - 1975 - Softcover. Robinson Crusoe - Daniel Defoe Publisher, Norton, 1975 ; Original from, the University of Michigan ; Digitized, Jan 20, 2010 ; ISBN, 0393044076, 9780393044072 ; Length, 399 pages. Robinson Crusoe (A Norton Critical Edition) Robinson Crusoe (A Norton Critical Edition) is a Used Trade Paperback available to purchase and shipped from Firefly Bookstore in Kutztown, PA. The Crowthers of Bankdam The Crowthers of Bankdam is a 1940 historical novel by the British writer Thomas Armstrong. His debut novel, it is a family saga following the fortunes of ... The Crowthers of Bankdam THE story of three generations of a family of mill owners in the West Riding of Yorkshire, between 1854 and 1921, told with Victorian fullness, leisureliness, ... The Crowthers of Bankdam by Thomas Armstrong Read 9 reviews from the world's largest community for readers. The Crowthers of Bankdam is the story of a great Yorkshire wool-trade family, as fascinating... The Crowthers of Bankdam: Armstrong, Thomas A wonderful old novel which combines a captivating story about the fictional Crowther family with a vivid description of life in 19th century Yorkshire, England ... The Crowthers of Bankdam: Armstrong. Thomas. A

wonderful old novel which combines a captivating story about the fictional Crowther family with a vivid description of life in 19th century Yorkshire, England ... The Crowthers of Bankdam by Armstrong, Thomas 1st Edition. - Hardcover - The Macmillan Company, New York - 1941 - Condition: Near Fine - Near Fine - 8vo. First edition. 623 p.p. Black cloth boards with ... The Crowthers of Bankdam by ARMSTRONG, Thomas Collins - 1940 - 1st edition. Very light foxing on page edges and endpapers; otherwise a tidy copy in tight binding. Green cloth a bit faded on spine with ... The Crowthers of Bankdam | Thomas Armstrong | 1st Edition The Crowthers of Bankdam ... First edition. 623 p.p. Black cloth boards with silver lettering to spine. Spine ends bumped, else fine. Dust jacket is price clipped ... 1947 The Crowthers of Bankdam Thomas Armstrong We travel constantly from the Florida Keys to the mountains of Eastern Kentucky searching for the odd and unusual. We work with a team of pickers that are ... The Crowthers of Bankdam - by Armstrong, Thomas 1st Edition. Hardcover. Near Fine/Near Fine. 8vo. First edition. 623 p.p. Black cloth boards with silver lettering to spine. Spine ends bumped, else fine. Dust ...